

EP2 Hose Pump

3A1940G
EN

Electric-powered hose pump for use in fluid transfer and metering applications. For professional use only.

Not approved for use in explosive atmospheres or hazardous locations.



Important Safety Instructions

Read all warnings and instructions in this manual. Save these instructions.

125 psi (0.9 MPa, 9 bar) Maximum Fluid Working Pressure

See page 2 for model part numbers and information.

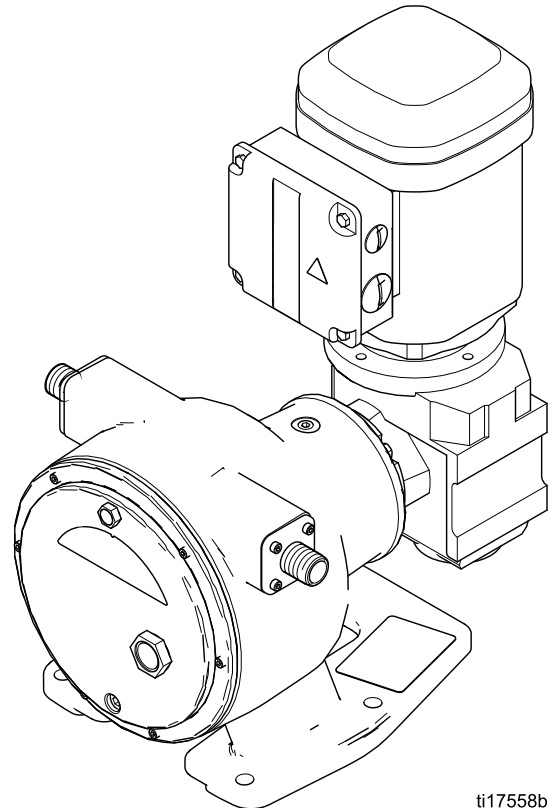

ti17558b



Contents



Models	2	EP2 Hose Pump Assembly	18
Warnings	3	Bare Pump Assembly	20
Troubleshooting.....	6	Pump Matrix	22
Repair.....	8	Pump Kit Matrix	24
Before You Start	8	Variable Frequency Drives (VFD).....	27
Disassembly	8	Notes.....	28
Reassembly	12	Technical Data	29
Notes	17	Graco Standard Warranty.....	30
Parts.....	18		





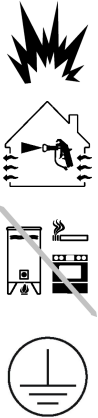

Models

Pump Model	Hose ID Size (mm)	Reference
EP2006	6	See Model EP2006 Pumps, page 22 for a complete list of pump part numbers and descriptive information.
EP2013	13	See Model EP2013 Pumps, page 23 for a complete list of pump part numbers and descriptive information.

Warnings

The following warnings are for the setup, use, grounding, maintenance and repair of this equipment. The exclamation point symbol alerts you to a general warning and the hazard symbol refers to procedure-specific risks. When these symbols appear in the body of this manual or on warning labels, refer back to these Warnings. Product-specific hazard symbols and warnings not covered in this section may appear throughout the body of this manual where applicable.

 WARNING	
	<p>FIRE AND EXPLOSION HAZARD</p> <p>Flammable fumes, such as solvent and paint fumes, in work area can ignite or explode. To help prevent fire and explosion:</p> <ul style="list-style-type: none"> • Use equipment only in well ventilated area. • Eliminate all ignition sources; such as pilot lights, cigarettes, portable electric lamps, and plastic drop cloths (potential static arc). • Keep work area free of debris, including solvent, rags and gasoline. • Do not plug or unplug power cords, or turn power or light switches on or off when flammable fumes are present. • Ground all equipment in the work area. See Grounding instructions. • Use only grounded hoses. • Hold gun firmly to side of grounded pail when triggering into pail. • If there is static sparking or you feel a shock, stop operation immediately. Do not use equipment until you identify and correct the problem. • Keep a working fire extinguisher in the work area.
	<p>ELECTRIC SHOCK HAZARD</p> <p>This equipment must be grounded. Improper grounding, setup, or usage of the system can cause electric shock.</p> <ul style="list-style-type: none"> • Turn off and disconnect power at main switch before disconnecting any cables and before servicing or installing equipment. • Connect only to grounded power source. • All electrical wiring must be done by a qualified electrician and comply with all local codes and regulations.
	<p>MOVING PARTS HAZARD</p> <p>Moving parts can pinch, cut or amputate fingers and other body parts.</p> <ul style="list-style-type: none"> • Keep clear of moving parts. • Do not operate equipment with protective guards or covers removed. • Pressurized equipment can start without warning. Before checking, moving, or servicing equipment, follow the Pressure Relief Procedure and disconnect all power sources.

 <h1 style="margin: 0;">WARNING</h1>	
 	<p>ENTANGLEMENT HAZARD Rotating parts can cause serious injury.</p> <ul style="list-style-type: none"> • Keep clear of moving parts. • Do not operate equipment with protective guards or covers removed. • Do not wear loose clothing, jewelry or long hair while operating equipment. • Equipment can start without warning. Before checking, moving or servicing equipment, follow the Pressure Relief Procedure and disconnect all power sources.
	<p>TOXIC FLUID OR FUMES Toxic fluids or fumes can cause serious injury or death if splashed in the eyes or on skin, inhaled, or swallowed.</p> <ul style="list-style-type: none"> • Read MSDSs to know the specific hazards of the fluids you are using. • Store hazardous fluid in approved containers, and dispose of it according to applicable guidelines.
	<p>PERSONAL PROTECTIVE EQUIPMENT You must wear appropriate protective equipment when operating, servicing, or when in the operating area of the equipment to help protect you from serious injury, including eye injury, hearing loss, inhalation of toxic fumes, and burns. This equipment includes but is not limited to:</p> <ul style="list-style-type: none"> • Protective eyewear, and hearing protection. • Respirators, protective clothing, and gloves as recommended by the fluid and solvent manufacturer.
	<p>PRESSURIZED EQUIPMENT HAZARD Fluid from the equipment leaks, or ruptured components can splash in the eyes or on skin and cause serious injury.</p> <ul style="list-style-type: none"> • Follow the Pressure Relief Procedure when you stop spraying/dispensing and before cleaning, checking, or servicing equipment. • Tighten all fluid connections before operating the equipment. • Check hoses, tubes, and couplings daily. Replace worn or damaged parts immediately.



WARNING



EQUIPMENT MISUSE HAZARD

Misuse can cause death or serious injury.

- Do not operate the unit when fatigued or under the influence of drugs or alcohol.
- Do not exceed the maximum working pressure or temperature rating of the lowest rated system component. See **Technical Data** in all equipment manuals.
- Use fluids and solvents that are compatible with equipment wetted parts. See **Technical Data** in all equipment manuals. Read fluid and solvent manufacturer's warnings. For complete information about your material, request MSDS from distributor or retailer.
- Do not leave the work area while equipment is energized or under pressure.
- Turn off all equipment and follow the **Pressure Relief Procedure** when equipment is not in use.
- Check equipment daily. Repair or replace worn or damaged parts immediately with genuine manufacturer's replacement parts only.
- Do not alter or modify equipment.
- Use equipment only for its intended purpose. Call your distributor for information.
- Route hoses and cables away from traffic areas, sharp edges, moving parts, and hot surfaces.
- Do not kink or over bend hoses or use hoses to pull equipment.
- Keep children and animals away from work area.
- Comply with all applicable safety regulations.

Troubleshooting

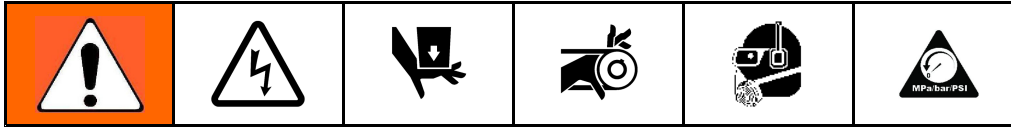

NOTE: Check all possible remedies before disassembling the pump.

Problem	Cause	Solution
Hammering in piping.	Inlet or outlet pipe diameters too small.	Increase pipe size or add pulsation dampeners.
	High pump speed.	Reduce speed of pump.
	Inlet or outlet connections not properly anchored.	Secure piping.
	High inlet or outlet pressures.	Add pulsation dampeners.
High pump temperature.	Low lubricant level.	Add hose lube to the proper level.
	Improper lubricant.	Use only Graco hose lube for low temperature operation.
	Pumped fluid temperature too high.	Consult your Graco distributor for maximum temperature limits of your pump.
	High pump speed/pump undersized.	Reduce the pump speed or switch to a larger pump.
High outlet pressure.	Blocked outlet line.	Clear any obstructions in the outlet line.
	Narrowed pipe diameter due to settled solids.	Determine if solids have settled in piping and flush/remove as required.
	Viscosity or specific gravity of pumped fluid too high.	Consult your Graco distributor for suitable operating conditions for your pump.
Low inlet pressure.	Failed hose.	Check to see if the hose has failed. If so, replace with a new hose and lubricant.
	Blocked inlet line.	Clear any obstructions in the inlet line.
	Inlet line too long or too small.	Try to locate the pump as near to the fluid source as possible. Oversize the inlet piping when possible.
	Viscosity or specific gravity of pumped fluid too high.	Consult your Graco distributor for suitable operating conditions for your pump.
Low flow.	Failed hose.	Check to see if the hose has failed. If so, replace with a new hose and lubricant.

Problem	Cause	Solution
Poor hose life.	Chemical incompatibility.	Consult your Graco distributor to see if you have the correct hose for your application.
	Normal wear.	The hose may have failed due to normal wear. Replace as required.
	Failure due to pulsations.	If your pump is equipped with a pulsation dampener, adjust its pressure. If you do not have a dampener, consult your Graco distributor.
	Too high outlet pressure.	Check items listed in "High outlet pressure." Running the pump against a closed valve, even for a short amount of time, may damage hose.
	Settled solids in hose.	Flush the pump and hose prior to turning the pump off.
Lubricant leaks.	Hose lube leaking from front cover.	Cover bolts over-tightened. Refer to torque specifications in Install the Front Cover, page 16 .
	Hose lube leaking from hose clamps.	Pump housing overfilled. Check hose lube level and adjust as necessary.
Hose failed because it wrapped around roller.	Pump was operated against a closed outlet valve or blocked line.	Replace hose. Check pressure relief system. Check that valves are open. Clear any blockages.

Repair

Before You Start

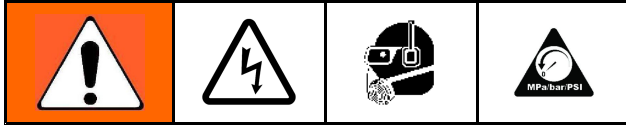

1. Flush the pump.
2. Relieve the pressure.
3. Disconnect power to the pump.
4. Make sure the pump is electrically isolated. Unexpected operation of the pump can cause serious injury. Remove the fan cover only after the motor has been locked out.

Disassembly

Drain the Oil

1. Hold a pail under the drain plug (17) and unscrew the plug to drain the lubricating oil. Dispose of the oil properly. Take care, as the oil may be contaminated by the pumped fluid.
2. Remove the vent plug (15) and flush the pump housing with a compatible solvent.

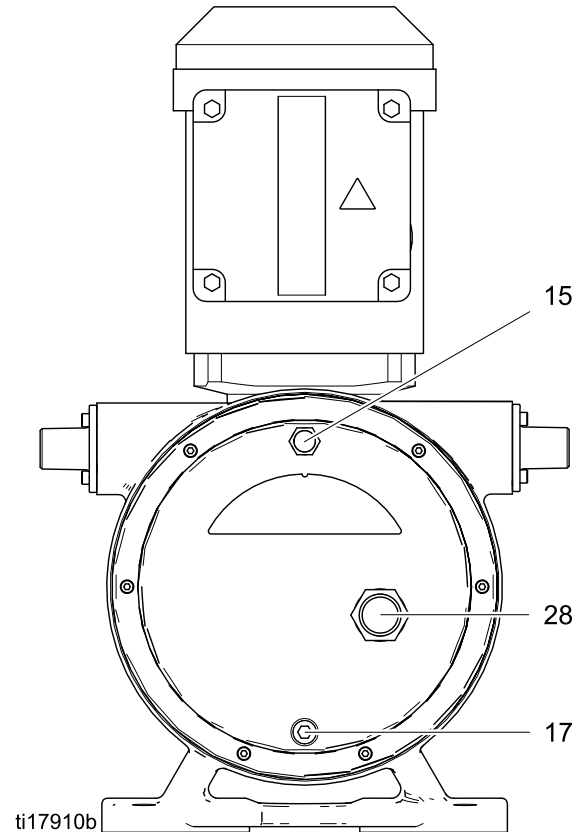

Figure 1 Pump Drain and Vent

Remove the Front Cover

1. Unscrew the socket head cap screws (14) and washers (13) that hold the front cover (12), removing the top screw and washer last. Take the cover off the pump. See Figure 5, page 11.
2. Remove the front cover gasket (11).
3. Inspect and clean the cover (12), then set aside.

Remove the Hose

1. See Figure 5, page 11. Remove the screws holding the motor fan cover (FC). Turn the fan by hand until the roller (102) stops at the bottom of the pump housing (1) in the 6 o'clock position.

NOTE: Low RPM pumps and high ratio gearboxes may require many turns of the motor fan to move the roller to the 6 o'clock position.

2. Remove the four screws (115) from the barbed fitting (105) on the inlet and outlet ports of the pump.
3. Gently pull the barbed fittings (105) away from the pump housing (1) so the hose extends about 2–3 in. (51–76 mm) out of the pump.
4. If possible, ensure that the hose clamps (104) are positioned with the clamp portion at the top. Cut through the clamp with a hack saw or rotary tool. Be careful not to damage the hose (103) or the pump housing (1).

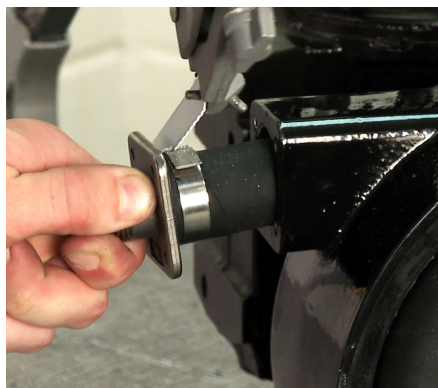

Figure 2 Cut the Clamp

5. Using a screwdriver, remove the clamp, then remove the band.

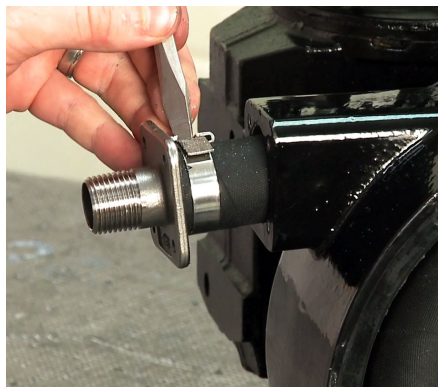

Figure 3 Remove the Clamp

6. Remove one barbed fitting (105) from the hose (103).
7. Grasp the hose (103) from the inside of the pump housing (1) and pull it into the housing. The center of the hose will still be held by the roller in the 6 o'clock position.
8. Remove the second barb assembly as described above.
9. Turn the motor by hand until the roller (102) is not compressing the hose (103). This will be near the 9 o'clock or 3 o'clock position.

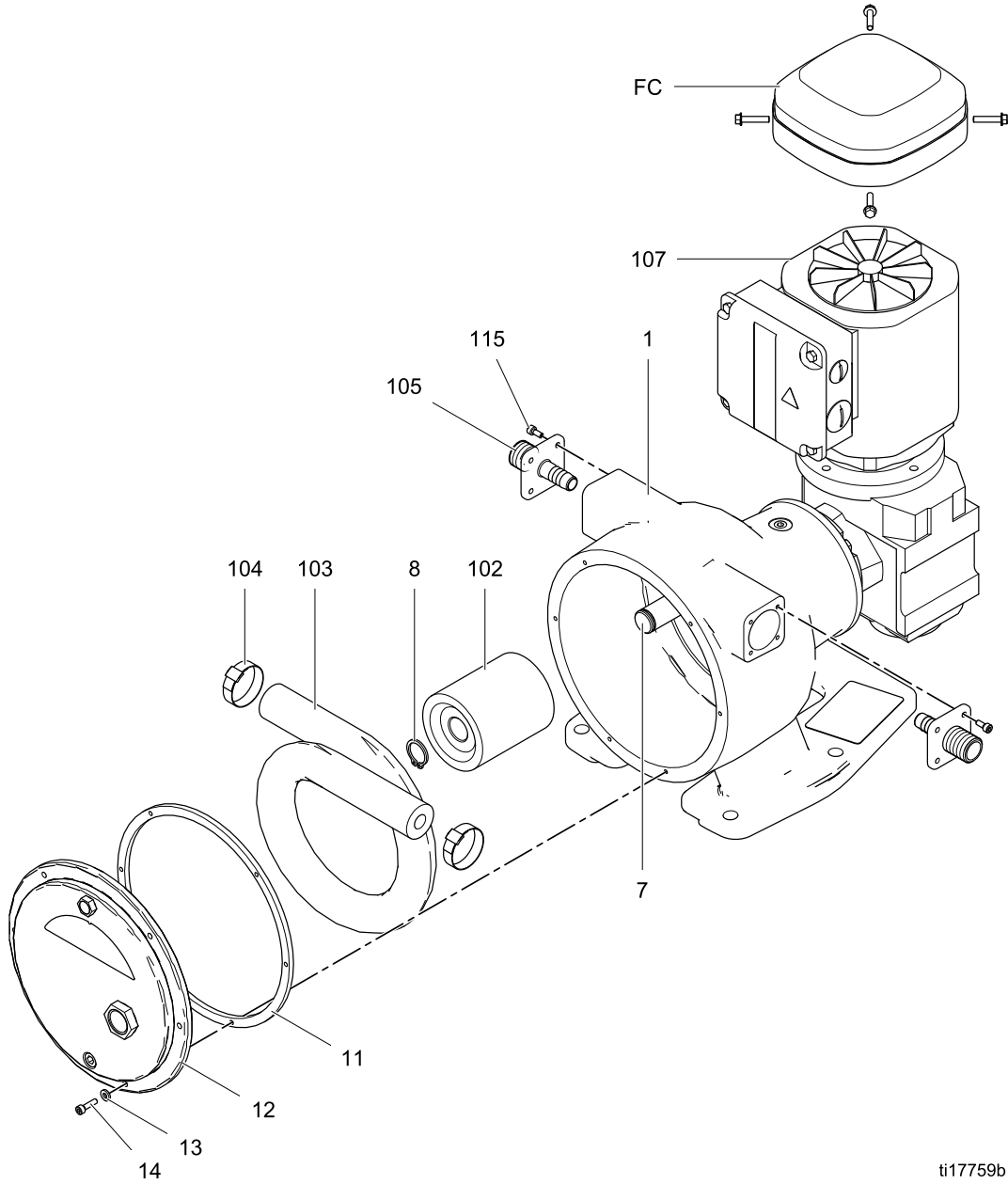

Figure 4 Roller in 9 O'Clock Position

10. Pull the other end of the hose into the pump housing (1).
11. Remove and safely discard the used hose, per your facility's waste disposal policy.

Remove the Roller

1. Using external snap ring pliers, remove the roller retaining ring (8) from the front of the eccentric shaft (7).
2. Pull the roller (102) off the shaft. It should slide off easily.
3. Inspect the inside and outside diameter of the roller (102), and replace it if worn or damaged.



ti17759b

Figure 5 Remove the Hose and Roller

Remove the Eccentric Shaft

1. Using external snap ring pliers, remove the eccentric shaft retaining ring (8) from the motor output shaft (2).
2. Remove the eccentric shaft (7) from the motor output shaft. **Be sure to retain the eccentric shaft key (6).**

NOTE: You may need to use a puller to disengage the eccentric shaft from the motor output shaft.

Remove the Motor Output Shaft

NOTE: The motor output shaft is held in place with a retaining ring (3) located behind the outer u-cup seal (4). The outer seal must be removed before removing the retaining ring. This seal will likely be damaged when removed since it is held in place by a tight press fit.

1. Using a flat head screw driver, remove the outer u-cup seal (4).
2. Using internal snap ring pliers, remove the retaining ring (3) from the pump housing (1).
3. Remove the four screws (109) and washers (108) holding the gearbox and motor assembly (107) to the pump housing (1). Remove the gearbox and motor assembly to allow access to the inner u-cup seal (5). **Be sure to retain the motor output shaft key (106).**

NOTE: For motor and gearbox repair information, contact SEW-Eurodrive.

4. Remove the inner u-cup seal (5). This seal will likely be damaged when removed since it is held in place by a tight press fit.
5. Tap the gearbox end of the shaft (2) with a rubber mallet to drive the shaft out through the front of the pump housing (1).

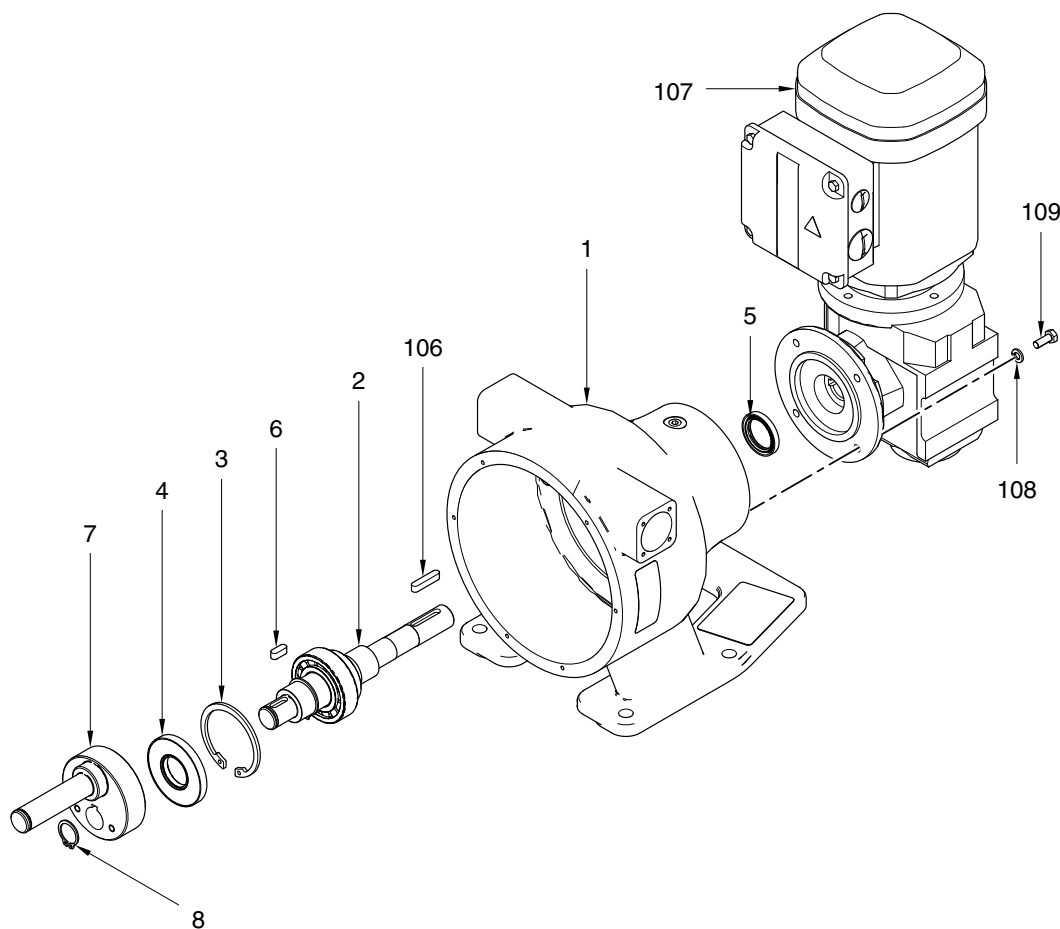

Figure 6 Remove the Eccentric Shaft and Motor Output Shaft

Reassembly

Clean and Inspect All Parts

NOTICE

Use only genuine Graco replacement parts. Non-standard parts will void your warranty and may damage your equipment.

- Discard all used seals, gaskets and worn parts.
- Ensure that all new and existing parts are clean and undamaged.
- Thoroughly clean all parts with a compatible solvent and inspect for damage or wear. Replace all gaskets, washers, worn parts and hardware as necessary.
- Inspect the inner diameter of the pump roller. If the surface has been worn, replace the roller.
- Inspect the bearings on the motor output shaft (2). If the bearings are worn, replace the shaft.
- Inspect the shaft and bearing bore in the pump housing (1). Ensure it is round, without grooves or other signs of wear, and free of dirt, filings, or other debris. A dirty or damaged bearing bore will greatly reduce the life of the bearings.
- Inspect all metal parts for signs of wear or cracks. Replace all worn parts.

NOTICE

The pump housing is aluminum. To help prevent galling, blow out the threads with compressed air before installing any fittings or fasteners.

Install the Motor Output Shaft

1. Inspect the bearings and make sure that all rotate freely and are seated against the shoulder of the shaft (2). See Figure 6.

2. Coat the outer races of the shaft bearings and the inner diameter of the bearing bore with light lubricating oil. Make sure there is no dirt or debris on either the bearings or the bearing bore.
3. Insert the shaft (2) into the pump housing (1) from the front, making sure that the bearings engage the bearing bore flush and straight. Tap the roller end of the shaft with a rubber mallet until the shaft is firmly seated in the pump housing.

NOTICE

Do not force the shaft and bearings into the pump housing. This may cause damage to the bearings or the housing.

4. Install the bearing retaining ring (3) in front of the outer bearing.

Install the Seals

1. Press a new inner u-cup seal (5) onto the gearbox end of the shaft (2) and into the bore at the rear of the pump housing (1). The lips of the u-cup must face into the pump housing. See Figure 7.
2. Grease the pump with NLGI #2 type grease. Remove the plug (18) from the pump housing and replace it with a zerk fitting. Add grease until it passes through the outer bearing of the shaft. This provides a visual reference of the proper amount of grease. Do not over-grease. Remove the zerk fitting and reinstall the plug (18).
3. Press a new outer u-cup seal (4) onto the pump end of the shaft (2) and into the bore at the front of the pump housing (1). The lips of the u-cup must face toward the shaft bearings.
4. Make sure that the shaft rotates smoothly.

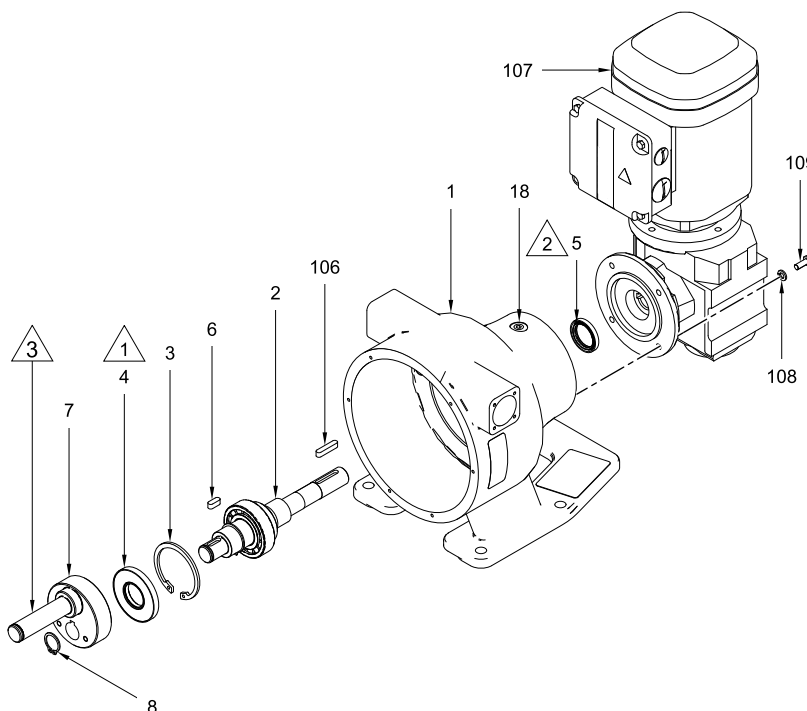

Figure 7 Install the Motor Output Shaft and Eccentric Shaft

Key for Figure 7	
Note	Description
△1	Lips of the u-cup (4) must face toward the shaft bearings.
△2	Lips of the u-cup (5) must face into the pump housing.
△3	Lubricate with hose lube.

Install the Motor and Gearbox

1. Lubricate the motor output shaft (2) and the keyway with an anti-seize compound.
2. The gearbox is manufactured with a hollow bore. Remove the plastic cap on the back of the gearbox to help with alignment of the shaft.
3. Slide the motor and gearbox assembly (107) onto the shaft (2). Typically the assembly is mounted with the motor above the gearbox. Install the key (106). Secure to the pump housing (1) with the four screws (109) and washers (108).

Install the Eccentric Shaft

1. Ensure that the keyway on the motor output shaft (2) is facing up. It may be necessary to turn the motor fan by hand to position the shaft.

2. Slide the eccentric shaft (7) over the end of the motor output shaft (2). Install the key (6). The eccentric and the key should slide easily together.
3. Secure the eccentric shaft (7) with the eccentric shaft retaining ring (8).

Install the Roller

NOTE: The roller size is typically marked on the roller. Verify that you have the correctly sized roller.

1. Lubricate the eccentric shaft (7) with hose lube. Slide the roller (102) onto the shaft. The roller should fit onto the shaft snugly with minimal radial movement. See Figure 8.
2. Install the roller retaining ring (8). Verify that the roller (102) turns freely on the shaft (7).

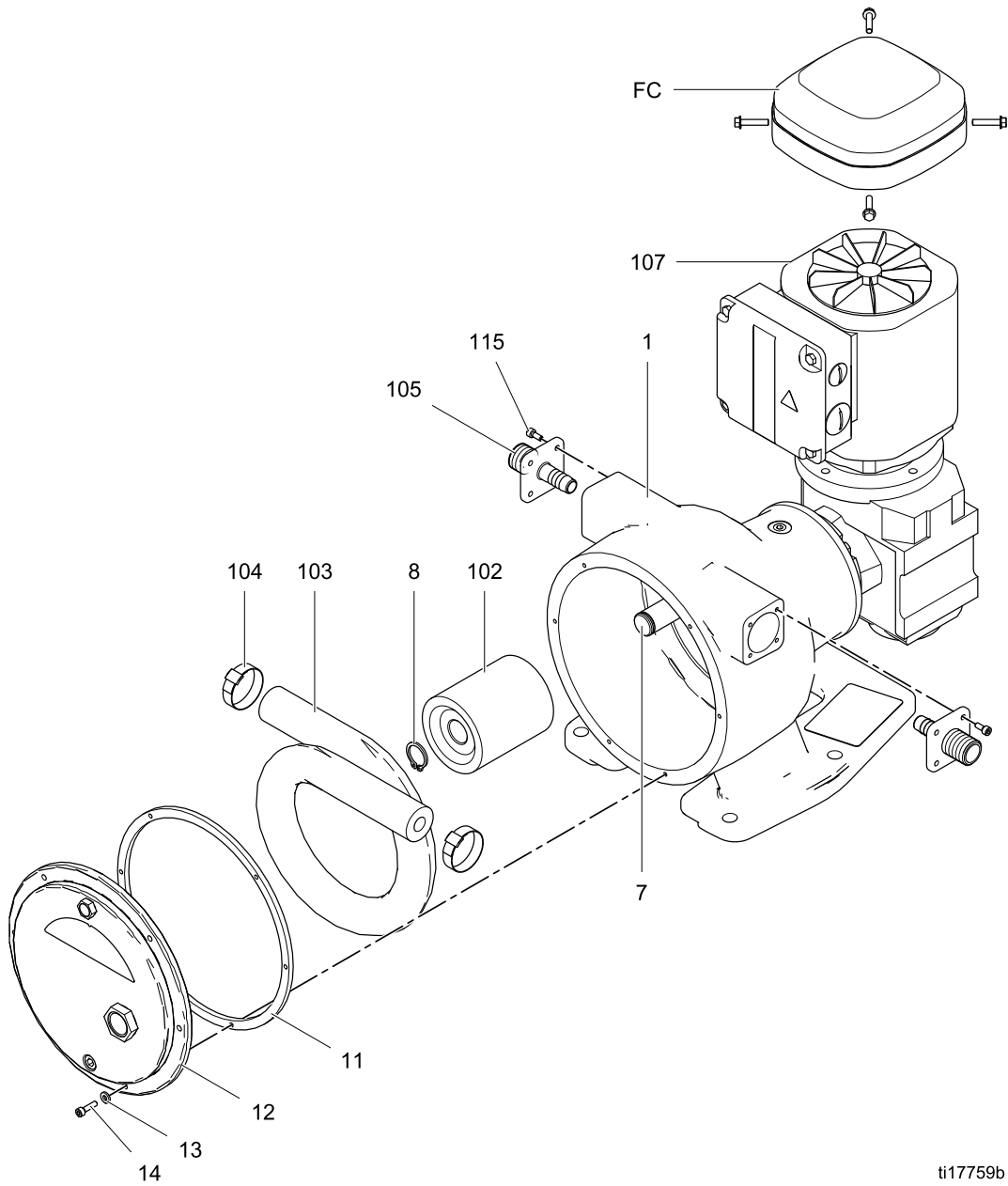

ti17759b

Figure 8 Install the Roller, Hose, and Front Cover

Key for Figure 8	
Note	Description
4	Torque to 115 in-lb (13.0 N•m).
5	Torque to 25 in-lb (2.8 N•m).

Install the Hose

1. Move the roller (102) by turning the motor fan until the roller reaches the 6 o'clock position.



Figure 9 Roller in 6 O'Clock Position

2. Install one end of the hose (103) through the rear port of the pump housing on the left hand side when looking at it from the front. Extend the hose 2-3 in. (51-76 mm) beyond the pump housing (1).
3. Slide the hose clamp (104) over the hose and install the barbed fitting (105).
4. Position the hose clamp about 1/4 in. (6 mm) from the end of the hose. Using the 24L497 Clamping Tool, tighten the clamp to secure the hose onto the barbed fitting.



Figure 10 Tighten the Clamp

5. Cut the excess band, then flatten the end with a rubber mallet.



Figure 11 Flatten the Band

6. Install the screws (115) and torque to 115 in-lb (13.0 N•m).
7. Loop the hose (103) 360 degrees and pass the other end through the front port on the right hand side of the pump housing (1). Assemble the barbed fitting (105) and clamp (104) as explained in steps 3-6.
8. Turn the roller (102) to the 12 o'clock position and push the hose into the pump housing. Use a rubber mallet if the hose is difficult to seat.
9. Return the roller (102) to the 6 o'clock position, compressing the hose. It is critical that the roller is at the bottom of the pump to ensure the correct capacity of hose lube. Reinstall the motor fan cover.

NOTICE

The roller must be returned to the 6 o'clock position before installing the front cover. Failure to do so will result in overfilling of the pump with hose lube.

Install the Front Cover

1. Scrape all debris from the gasket mating surfaces on the front cover (12) and the pump housing (1), then clean with acetone or brake cleaner to remove any residue. This is critical to ensure a leak-free assembly.

NOTE: The pump housing and front cover must be free of dirt, debris and residue to ensure a leak-free seal.

2. Place a bead of compatible sealant on the gasket surface of the front cover (12), to hold the gasket in place during assembly.

NOTE: The hole pattern of the front cover (12), gasket (11), and housing are asymmetric. This ensures that the gasket and cover go on in only one direction.

3. Line up the holes in the gasket (11) with the holes in the cover (12) before placing the gasket on the sealant bead. Place the gasket on the cover.
4. Line up the front cover and gasket with the pump housing (1) by placing a socket head cap screw (14) and washer (13) in the top hole and screwing it into the pump housing (1).
5. Install the remaining front cover screws (14) and washers (13). Torque the screws oppositely to 25 in-lb (2.8 N•m).

NOTE: Do not over-tighten the front cover screws. This will cause the gasket to deform and the pump to leak.

Lubricate the Pump

1. Wrap the drain plug (17) threads with PTFE tape and install the plug.
2. Using a funnel, fill the pump housing with hose lube through the vent port. The pump will require approximately 8 oz (250 ml).

NOTE: Do not overfill. Overfilling the pump housing with hose lube will increase pressure in the pump housing, causing hose lube to leak

from the cover or the clamp area. Pre-measuring the correct amount will help prevent overfilling.

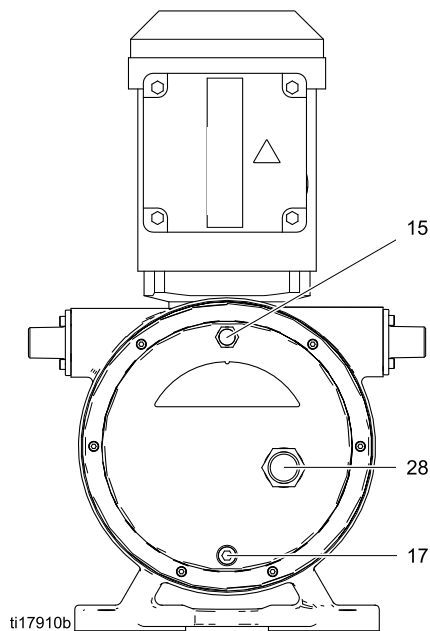

Figure 12 Lubricate through Vent Port (15)

3. Wrap the vent plug (15) threads with PTFE tape and screw it into the vent port carefully.

NOTE: Higher operating speeds provide more vigorous lubrication, which may cause splashing of oil. When operating at a speed of 85 RPM or greater, reduce the amount of hose lube as shown in the table below.

Operating Speed (RPM)	Reduction in Oil
0–84	Use quantity recommended in step 2.
85–104	Use 70% of recommended quantity
105–114	Use 60% of recommended quantity
115 and above	Use 50% of recommended quantity

Parts

EP2 Hose Pump Assembly

EP2006 and EP2013 Pumps, Series A

Includes items 101-119

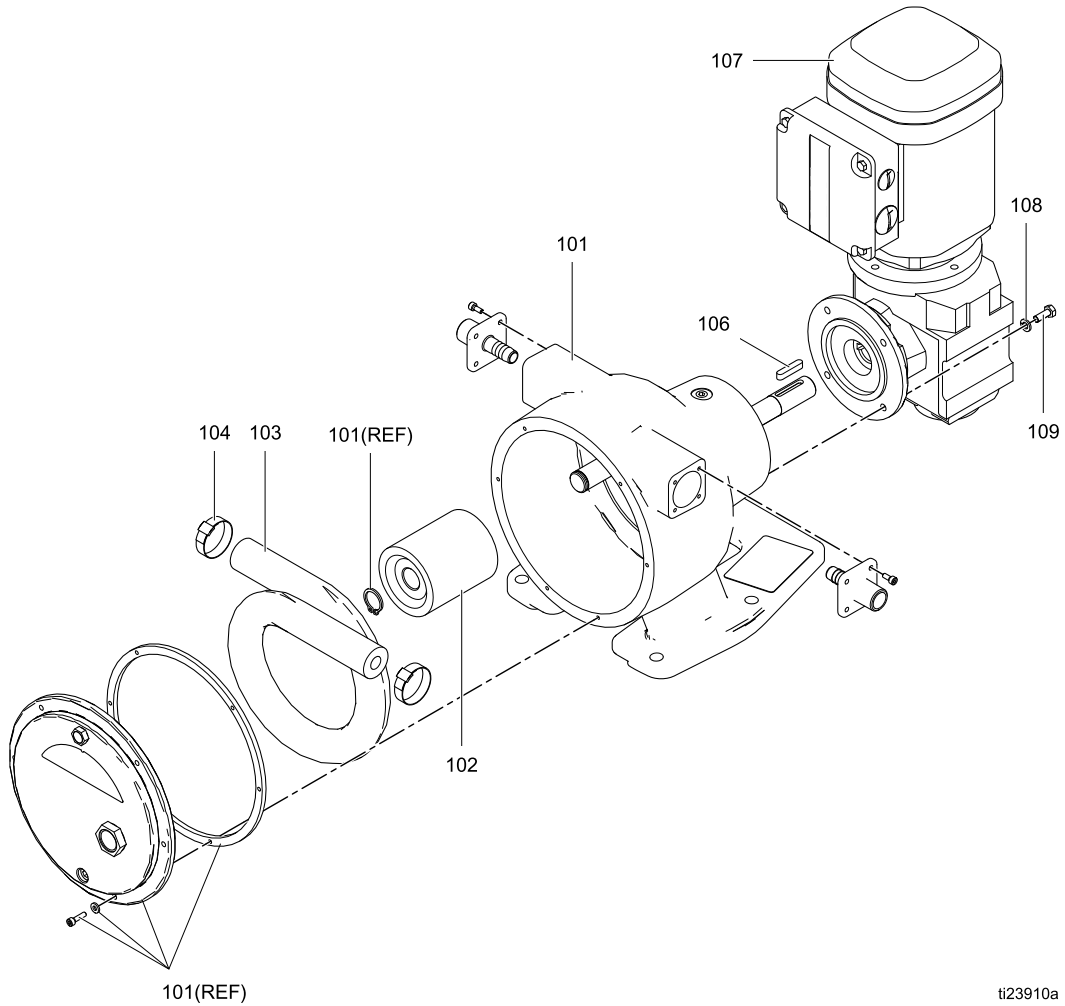

ti23910a

Ref. No.	Part No.	Description	Qty
101	24L887	ASSEMBLY, pump; see Bare Pump Assembly, page 20 .	1
102	24K562	ROLLER KIT; for EP2006; includes one of item 8 (page 21)	1
	24K564	ROLLER KIT; for EP2013; includes one of item 8 (page 21)	1
103	See Pump Matrix, page 22	HOSE KIT; includes two hose clamps (104)	1
104	24M116	KIT, hose clamp; package of 10	1
105	See Pump Matrix, page 22	BARBED FITTING KIT; kit includes one barbed fitting, one clamp (104), and four screws (115)	2
106	---	KEY, motor shaft	1

*u*Hose lube is also available in a 1 gallon (3.8 liter) bottle. Order Part No. 24K694.

Ref. No.	Part No.	Description	Qty
107		MOTOR and GEAR-BOX ASSEMBLY (see Pump Matrix, page 22 , for the motor and gearbox used on your pump)	1
	24L982	0.5 HP; 51.30 gear ratio; EP2006	
	24L983	0.75 HP; 35.10 gear ratio; EP2013	
	24L985	0.33 HP; 157.43 gear ratio; EP2006 and EP2013	
108	---	WASHER, split lock; M6	4
109	---	SCREW, cap, hex hd; M6 x 16 mm	4
115	---	SCREW, socket hd; M4 x 12 mm	8
119u	24K692	HOSE LUBE; glycerin; 1 quart (0.95 liter); not shown	1

Parts labeled --- are not available separately.

Bare Pump Assembly

Model 24L887 Pump Assembly, Series A
Includes items 1-23

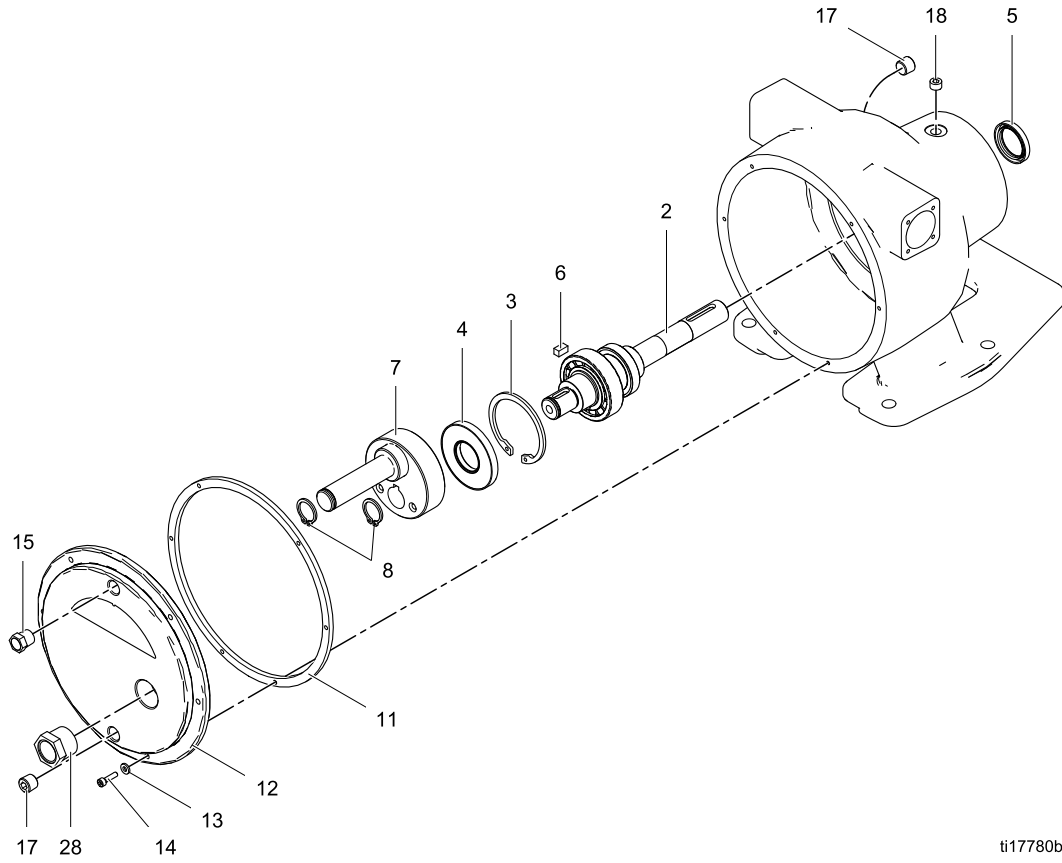

ti17780b

Ref. No.	Part No.	Description	Qty
1	---	HOUSING, pump	1
2	24K574	SHAFT KIT, output, motor; includes items 3, 4, 5, 6, 8, 18, and grease zerk fitting	1
3	---	RING, retaining, bearing	1
4	---	SEAL, u-cup, outer	1
5	---	SEAL, u-cup, inner	1
6	---	KEY, eccentric shaft	1
7	24K573	ECCENTRIC SHAFT KIT; includes items 6 and 8	1
8	---	RING, retaining, eccentric shaft	2

▲ Replacement Danger and Warning labels, tags, and cards are available at no cost.

Ref. No.	Part No.	Description	Qty
11	24K572	GASKET KIT	1
12	24K571	COVER KIT; includes items 11, 13, 14, 15, 17, and 28	1
13	---	WASHER, flat; no. 8	6
14	---	SCREW, cap, socket hd; M4 x 16 mm	6
15	---	VENT, breather plug	1
17	---	PLUG, drain; 1/4 npt	2
18	---	PLUG, pipe, headless; 1/8 npt	1
23 ▲	16K630	LABEL, warning; all models	1
28	---	SIGHTGLASS, 3/4 npt	1

Parts labeled --- are not available separately.

Pump Matrix

Model EP2006 Pumps

With 6 mm ID Hose and Roller Installed

Pump Part No.	Pump Series	Hose Kit (Ref. 103)	Hose Inner Material	Hose Stripe Color	Barbed Fitting Kit (Ref. 105)	Barbed Fitting Material	Motor and Gearbox (Ref. 107)
24L100	B	24K483	EPDM	Blue	24K565	SST	24L985
24L101	B	24K483	EPDM	Blue	24K566	Hastelloy	24L985
24L104	B	24K482	Natural Rubber	None	24K565	SST	24L985
24L105	B	24K487	CSM	Orange	24K565	SST	24L985
24L106	B	24K487	CSM	Orange	24K566	Hastelloy	24L985
24L107	B	24K484	Nitrile	Yellow	24K565	SST	24L985
24L108	B	24K484	Nitrile	Yellow	24K566	Hastelloy	24L985
24L114	B	24K483	EPDM	Blue	24K565	SST	24L982
24L115	B	24K483	EPDM	Blue	24K566	Hastelloy	24L982
24L118	B	24K482	Natural Rubber	None	24K565	SST	24L982
24L119	B	24K487	CSM	Orange	24K565	SST	24L982
24L120	B	24K487	CSM	Orange	24K566	Hastelloy	24L982
24L121	B	24K484	Nitrile	Yellow	24K565	SST	24L982
24L122	B	24K484	Nitrile	Yellow	24K566	Hastelloy	24L982
24L128	B	24K483	EPDM	Blue	24K565	SST	24L984
24L129	B	24K483	EPDM	Blue	24K566	Hastelloy	24L984
24L132	B	24K482	Natural Rubber	None	24K565	SST	24L984
24M735	A	24K483	EPDM	Blue	24K565	SST	None
24M736	A	24K483	EPDM	Blue	24K566	Hastelloy	None
24M739	A	24K482	Natural Rubber	None	24K565	SST	None
24M740	A	24K487	CSM	Orange	24K565	SST	None
24M741	A	24K487	CSM	Orange	24K566	Hastelloy	None
24M742	A	24K484	Nitrile	Yellow	24K565	SST	None
24M743	A	24K484	Nitrile	Yellow	24K566	Hastelloy	None
24W549	A	24K487	CSM	Orange	24V970	PVDF	24L982
24W550	A	24K487	CSM	Orange	24V970	PVDF	24L985
24W551	A	24K487	CSM	Orange	24V970	PVDF	None

* Food grade hose inner material is white in color.

Model EP2013 Pumps

With 13 mm ID Hose and Roller Installed

Pump Part No.	Pump Series	Hose Kit (Ref. 103)	Hose Inner Material	Hose Stripe Color	Barbed Fitting Kit (Ref. 105)	Barbed Fitting Material	Motor and Gearbox (Ref. 107)
24L184	B	24K503	EPDM	Blue	24K569	SST	24L985
24L185	B	24K503	EPDM	Blue	24K570	Hastelloy	24L985
24L188	B	24K502	Natural Rubber	None	24K569	SST	24L985
24L189	B	24K507	CSM	Orange	24K569	SST	24L985
24L190	B	24K507	CSM	Orange	24K570	Hastelloy	24L985
24L191	B	24K504	Nitrile	Yellow	24K569	SST	24L985
24L192	B	24K504	Nitrile	Yellow	24K570	Hastelloy	24L985
24L198	B	24K503	EPDM	Blue	24K569	SST	24L983
24L199	B	24K503	EPDM	Blue	24K570	Hastelloy	24L983
24L202	B	24K502	Natural Rubber	None	24K569	SST	24L983
24L203	B	24K507	CSM	Orange	24K569	SST	24L983
24L204	B	24K507	CSM	Orange	24K570	Hastelloy	24L983
24L205	B	24K504	Nitrile	Yellow	24K569	SST	24L983
24L206	B	24K504	Nitrile	Yellow	24K570	Hastelloy	24L983
24L212	B	24K503	EPDM	Blue	24K569	SST	24L984
24L213	B	24K503	EPDM	Blue	24K570	Hastelloy	24L984
24L216	B	24K502	Natural Rubber	None	24K569	SST	24L984
24M763	A	24K503	EPDM	Blue	24K569	SST	None
24M764	A	24K503	EPDM	Blue	24K570	Hastelloy	None
24M767	A	24K502	Natural Rubber	None	24K569	SST	None
24M768	A	24K507	CSM	Orange	24K569	SST	None
24M769	A	24K507	CSM	Orange	24K570	Hastelloy	None
24M770	A	24K504	Nitrile	Yellow	24K569	SST	None
24M771	A	24K504	Nitrile	Yellow	24K570	Hastelloy	None
24W552	A	24K507	CSM	Orange	24V971	PVDF	24L983
24W553	A	24K507	CSM	Orange	24V971	PVDF	24L985
24W554	A	24K507	CSM	Orange	24V971	PVDF	None

* Food grade hose inner material is white in color.

Pump Kit Matrix

Model EP2006 Pump Kits

With 6 mm ID Hose (installed) and Roller (not installed)

Pump Part No.	Roller Kit (Ref. 102)	Hose Kit (Ref. 103)	Hose Inner Material	Hose Stripe Color	Barbed Fitting Kit (Ref. 105)	Barbed Fitting Material	Motor and Gearbox (Ref. 107)
24L370	24K562	24K483	EPDM	Blue	24K565	SST	24L985
24L371	24K562	24K483	EPDM	Blue	24K566	Hastelloy	24L985
24L374	24K562	24K482	Natural Rubber	None	24K565	SST	24L985
24L375	24K562	24K487	CSM	Orange	24K565	SST	24L985
24L376	24K562	24K487	CSM	Orange	24K566	Hastelloy	24L985
24L377	24K562	24K484	Nitrile	Yellow	24K565	SST	24L985
24L378	24K562	24K484	Nitrile	Yellow	24K566	Hastelloy	24L985
24L384	24K562	24K483	EPDM	Blue	24K565	SST	24L982
24L385	24K562	24K483	EPDM	Blue	24K566	Hastelloy	24L982
24L388	24K562	24K482	Natural Rubber	None	24K565	SST	24L982
24L389	24K562	24K487	CSM	Orange	24K565	SST	24L982
24L390	24K562	24K487	CSM	Orange	24K566	Hastelloy	24L982
24L391	24K562	24K484	Nitrile	Yellow	24K565	SST	24L982
24L392	24K562	24K484	Nitrile	Yellow	24K566	Hastelloy	24L982
24L398	24K562	24K483	EPDM	Blue	24K565	SST	24L984
24L399	24K562	24K483	EPDM	Blue	24K566	Hastelloy	24L984
24L402	24K562	24K482	Natural Rubber	None	24K565	SST	24L984
24L403	24K562	24K487	CSM	Orange	24K565	SST	24L984
24L404	24K562	24K487	CSM	Orange	24K566	Hastelloy	24L984
24L405	24K562	24K484	Nitrile	Yellow	24K565	SST	24L984
24L406	24K562	24K484	Nitrile	Yellow	24K566	Hastelloy	24L984
24N020	24K562	24K483	EPDM	Blue	24K565	SST	None
24N021	24K562	24K483	EPDM	Blue	24K566	Hastelloy	None
24N024	24K562	24K482	Natural Rubber	None	24K565	SST	None
24N025	24K562	24K487	CSM	Orange	24K565	SST	None
24N026	24K562	24K487	CSM	Orange	24K566	Hastelloy	None
24N027	24K562	24K484	Nitrile	Yellow	24K565	SST	None
24N028	24K562	24K484	Nitrile	Yellow	24K566	Hastelloy	None

* Food grade hose inner material is white in color.

Model EP2013 Pump Kits

With 13 mm ID Hose (installed) and Roller (not installed)

Pump Part No.	Roller Kit (Ref. 102)	Hose Kit (Ref. 103)	Hose Inner Material	Hose Stripe Color	Barbed Fitting Kit (Ref. 105)	Barbed Fitting Material	Motor and Gearbox (Ref. 107)
24L454	24K564	24K503	EPDM	Blue	24K569	SST	24L985
24L455	24K564	24K503	EPDM	Blue	24K570	Hastelloy	24L985
24L458	24K564	24K502	Natural Rubber	None	24K569	SST	24L985
24L459	24K564	24K507	CSM	Orange	24K569	SST	24L985
24L460	24K564	24K507	CSM	Orange	24K570	Hastelloy	24L985
24L461	24K564	24K504	Nitrile	Yellow	24K569	SST	24L985
24L462	24K564	24K504	Nitrile	Yellow	24K570	Hastelloy	24L985
24L468	24K564	24K503	EPDM	Blue	24K569	SST	24L983
24L469	24K564	24K503	EPDM	Blue	24K570	Hastelloy	24L983
24L472	24K564	24K502	Natural Rubber	None	24K569	SST	24L983
24L473	24K564	24K507	CSM	Orange	24K569	SST	24L983
24L474	24K564	24K507	CSM	Orange	24K570	Hastelloy	24L983
24L475	24K564	24K504	Nitrile	Yellow	24K569	SST	24L983
24L476	24K564	24K504	Nitrile	Yellow	24K570	Hastelloy	24L983
24L482	24K564	24K503	EPDM	Blue	24K569	SST	24L984
24L483	24K564	24K503	EPDM	Blue	24K570	Hastelloy	24L984
24L486	24K564	24K502	Natural Rubber	None	24K569	SST	24L984
24L487	24K564	24K507	CSM	Orange	24K569	SST	24L984
24L488	24K564	24K507	CSM	Orange	24K570	Hastelloy	24L984
24L489	24K564	24K504	Nitrile	Yellow	24K569	SST	24L984
24L490	24K564	24K504	Nitrile	Yellow	24K570	Hastelloy	24L984
24N048	24K564	24K503	EPDM	Blue	24K569	SST	None
24N049	24K564	24K503	EPDM	Blue	24K570	Hastelloy	None
24N052	24K564	24K502	Natural Rubber	None	24K569	SST	None
24N053	24K564	24K507	CSM	Orange	24K569	SST	None
24N054	24K564	24K507	CSM	Orange	24K570	Hastelloy	None
24N055	24K564	24K504	Nitrile	Yellow	24K569	SST	None
24N056	24K564	24K504	Nitrile	Yellow	24K570	Hastelloy	None
24N048	24K564	24K503	EPDM	Blue	24K569	SST	None
24N049	24K564	24K503	EPDM	Blue	24K570	Hastelloy	None

Parts

Pump Part No.	Roller Kit (Ref. 102)	Hose Kit (Ref. 103)	Hose Inner Material	Hose Stripe Color	Barbed Fitting Kit (Ref. 105)	Barbed Fitting Material	Motor and Gearbox (Ref. 107)
24N052	24K564	24K502	Natural Rubber	None	24K569	SST	None
24N053	24K564	24K507	CSM	Orange	24K569	SST	None
24N054	24K564	24K507	CSM	Orange	24K570	Hastelloy	None
24N055	24K564	24K504	Nitrile	Yellow	24K569	SST	None
24N056	24K564	24K504	Nitrile	Yellow	24K570	Hastelloy	None

** Food grade hose inner material is white in color.*

Variable Frequency Drives (VFD)

VFD Part No.	Used With Pump	Horsepower	Input Voltage	Output Voltage
16K905	EP2006	0.5	120 or 240 Vac (1 phase)	240 Vac (3 phase)
16K906	EP2006	0.5	208–240 Vac (1 or 3 phase)	208–240 Vac (3 phase)
16K907	EP2013	1.0	120 or 240 Vac (1 phase)	240 Vac (3 phase)
16K908	EP2013	1.0	208–240 Vac (1 or 3 phase)	208–240 Vac (3 phase)

Technical Data

EP2 Pumps		
	U.S.	Metric
Maximum Fluid Working Pressure	125 psi	0.9 MPa, 9 bar
Motor Horsepower/Gear Ratio	See the Pump Matrix, page 22 , for the motor/gear ratio used on your pump: 0.5/51.30 0.75/35.10 0.33/157.43	
Maximum Pump Speed	6 mm: 35 rpm; 13 mm: 50 rpm	
Maximum Environmental Temperature	122°F	50°C
Minimum Environmental Temperature	14°F	-10°C
Maximum Flow		
EP2006 Pump	0.14 gpm	0.5 lpm
EP2013 Pump	0.80 gpm	3.0 lpm
Fluid Capacity per Revolution		
EP2006 Pump	0.004 gal.	0.015 liters
EP2013 Pump	0.016 gal.	0.06 liters
Hose Inner Diameter		
EP2006 Pump	6 mm	
EP2013 Pump	13 mm	
Noise		
Sound Pressure	Less than 80 dB(A)	
Dimensions		
Height	17.20 in.	437 mm
Width with hose installed	11.02 in.	280 mm
Width without hose installed	8.98 in.	228 mm
Length	13.35 in.	339 mm
Weight	51.7 lb	23.5 kg
Fluid Inlet and Outlet Size	1/2 npt(m)	
Wetted Parts		
Pump	Powder coated aluminum.	
Hose	See the Pump Matrix, page 22 .	
Barbed Fitting	Stainless steel or Hastelloy. See the Pump Matrix, page 22 .	

Graco Standard Warranty

Graco warrants all equipment referenced in this document which is manufactured by Graco and bearing its name to be free from defects in material and workmanship on the date of sale to the original purchaser for use. With the exception of any special, extended, or limited warranty published by Graco, Graco will, for a period of twelve months from the date of sale, repair or replace any part of the equipment determined by Graco to be defective. This warranty applies only when the equipment is installed, operated and maintained in accordance with Graco's written recommendations.

This warranty does not cover, and Graco shall not be liable for general wear and tear, or any malfunction, damage or wear caused by faulty installation, misapplication, abrasion, corrosion, inadequate or improper maintenance, negligence, accident, tampering, or substitution of non-Graco component parts. Nor shall Graco be liable for malfunction, damage or wear caused by the incompatibility of Graco equipment with structures, accessories, equipment or materials not supplied by Graco, or the improper design, manufacture, installation, operation or maintenance of structures, accessories, equipment or materials not supplied by Graco.

This warranty is conditioned upon the prepaid return of the equipment claimed to be defective to an authorized Graco distributor for verification of the claimed defect. If the claimed defect is verified, Graco will repair or replace free of charge any defective parts. The equipment will be returned to the original purchaser transportation prepaid. If inspection of the equipment does not disclose any defect in material or workmanship, repairs will be made at a reasonable charge, which charges may include the costs of parts, labor, and transportation.

THIS WARRANTY IS EXCLUSIVE, AND IS IN LIEU OF ANY OTHER WARRANTIES, EXPRESS OR IMPLIED, INCLUDING BUT NOT LIMITED TO WARRANTY OF MERCHANTABILITY OR WARRANTY OF FITNESS FOR A PARTICULAR PURPOSE.

Graco's sole obligation and buyer's sole remedy for any breach of warranty shall be as set forth above. The buyer agrees that no other remedy (including, but not limited to, incidental or consequential damages for lost profits, lost sales, injury to person or property, or any other incidental or consequential loss) shall be available. Any action for breach of warranty must be brought within two (2) years of the date of sale.

GRACO MAKES NO WARRANTY, AND DISCLAIMS ALL IMPLIED WARRANTIES OF MERCHANTABILITY AND FITNESS FOR A PARTICULAR PURPOSE, IN CONNECTION WITH ACCESSORIES, EQUIPMENT, MATERIALS OR COMPONENTS SOLD BUT NOT MANUFACTURED BY GRACO. These items sold, but not manufactured by Graco (such as electric motors, switches, hose, etc.), are subject to the warranty, if any, of their manufacturer. Graco will provide purchaser with reasonable assistance in making any claim for breach of these warranties.

In no event will Graco be liable for indirect, incidental, special or consequential damages resulting from Graco supplying equipment hereunder, or the furnishing, performance, or use of any products or other goods sold hereto, whether due to a breach of contract, breach of warranty, the negligence of Graco, or otherwise.

FOR GRACO CANADA CUSTOMERS

The Parties acknowledge that they have required that the present document, as well as all documents, notices and legal proceedings entered into, given or instituted pursuant hereto or relating directly or indirectly hereto, be drawn up in English. Les parties reconnaissent avoir convenu que la rédaction du présente document sera en Anglais, ainsi que tous documents, avis et procédures judiciaires exécutés, donnés ou intentés, à la suite de ou en rapport, directement ou indirectement, avec les procédures concernées.

Graco Information

To place an order, contact your Graco Distributor or call to identify the nearest distributor.

Phone: 612-623-6921 **or Toll Free:** 1-800-328-0211 **Fax:** 612-378-3505

All written and visual data contained in this document reflects the latest product information available at the time of publication. Graco reserves the right to make changes at any time without notice.

Original Instructions. This manual contains English, MM 3A1940
For patent information, see www.graco.com/patents.

Graco Headquarters: Minneapolis
International Offices: Belgium, China, Japan, Korea

GRACO INC. AND SUBSIDIARIES • P.O. BOX 1441 • MINNEAPOLIS, MN 55440-1441 • USA
Copyright 2011, Graco Inc. All Graco manufacturing locations are registered to ISO 9001.

www.graco.com
Revision G, July 2014